



GP 1272

12V 7.2Ah

GP 1272 is a general purpose battery with 3-5 years in standby service or more than 260 cycles at 100% discharge in cycle service. As with all CSB batteries, all are rechargeable, highly efficient, leak proof and maintenance free.



Specification

Cells Per Unit	6
Voltage Per Unit	12
Capacity	7.2Ah @ 20hr-rate to 1.75V per cell @25 °C(77°F)
Weight	Approx. 2.58kg(5.67 lbs)
Maximum Discharge Current	100A/130A(5sec)
Internal Resistance	Approx. 25mΩ
Operating Temperature Range	Discharge: -20°C~50°C(-4°F~122°F) Charge: 0°C~40°C(32°F~104°F) Storage: -20°C~40°C(-4°F~104°F)
Nominal Operating Temperature Range	25°C±3°C(77°F±5°F)
Float Charging Voltage	13.5 to 13.8 VDC/unit Average at 25°C(77°F)
Recommended Maximum Charging Current Limit	2.16A
Equalization and Cycle Service	14.4 to 15.0 VDC/unit Average at 25°C(77°F)
Self Discharge	CSB Batteries can be stored for more than 6 months at 25°C(77°F). Please charge batteries before using. For higher temperatures the time interval will be shorter.
Terminal	Faston Tab 187/250
Container Material	-ABS (UL94-HB)*Flammability resistance of UL94-V2 can be available upon request.



CSB-manufactured batteries are UL-recognized components under UL924 and UL1989. CSB is also certified by ISO 9001 and ISO 14001.

Dimensions

unit: (MM)

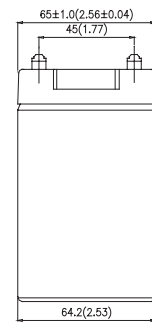
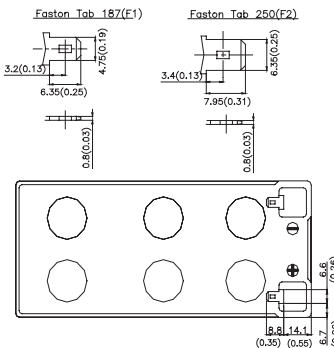
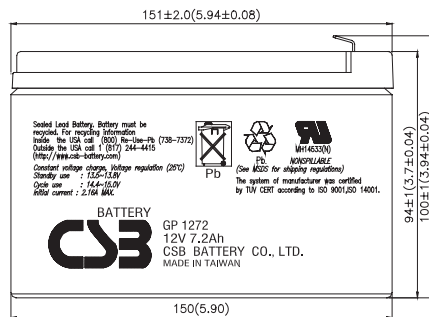

Constant Current Discharge Characteristics Unit:A (25°C, 77°F)

F.V.	5MIN	10MIN	15MIN	30MIN	1HR	2HR	3HR	4HR	5HR	8HR	10HR	20HR
1.60V	28.6	18.6	14.3	8.75	5.28	3.06	2.18	1.72	1.42	0.930	0.760	0.400
1.67V	26.8	17.9	13.9	8.69	5.27	3.05	2.17	1.71	1.41	0.930	0.753	0.386
1.70V	26.0	17.6	13.8	8.67	5.26	3.05	2.17	1.71	1.41	0.930	0.750	0.380
1.75V	24.3	16.8	13.3	8.55	5.24	3.03	2.16	1.71	1.41	0.925	0.740	0.370
1.80V	22.5	16.0	12.8	8.42	5.22	3.00	2.15	1.70	1.40	0.920	0.730	0.360
1.85V	20.8	15.2	12.4	8.30	5.20	2.98	2.14	1.70	1.40	0.915	0.720	0.350

Constant Power Discharge Characteristics Unit:W (25°C, 77°F)

F.V.	5MIN	10MIN	15MIN	30MIN	1HR	2HR	3HR	4HR	5HR	8HR	10HR	20HR
1.60V	343	223	171	105	63.4	36.6	26.2	20.7	17.0	11.2	9.10	4.74
1.67V	321	215	167	104	63.2	36.4	26.1	20.6	16.9	11.1	9.02	4.62
1.70V	312	211	165	104	63.1	36.3	26.0	20.6	16.9	11.1	8.99	4.57
1.75V	291	202	160	103	62.9	36.2	25.9	20.6	16.9	11.0	8.87	4.44
1.80V	270	192	154	101	62.6	36.0	25.8	20.5	16.8	10.9	8.75	4.31
1.85V	249	183	149	100	62.4	35.9	25.7	20.5	16.8	10.8	8.63	4.18

● All mentioned values are average values.

Trickle (or Float) Service Life

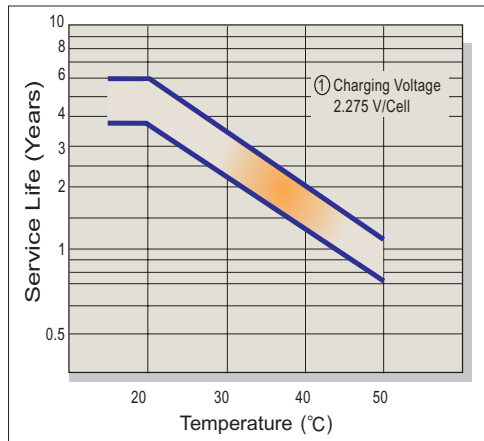

Capacity Retention Characteristic

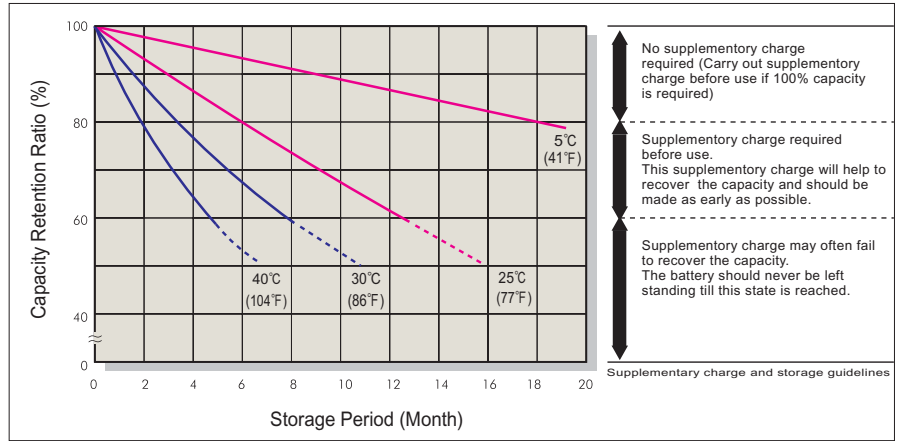

Battery Voltage and Charge Time for Standby Use

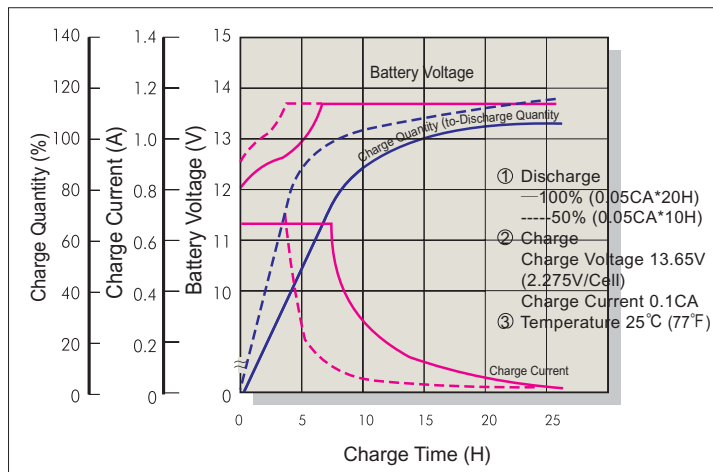

Cycle Service Life

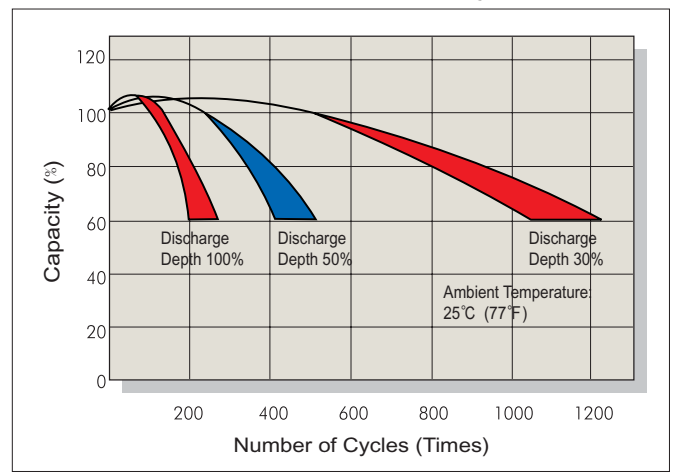

Battery Voltage and Charge Time for Cycle Use

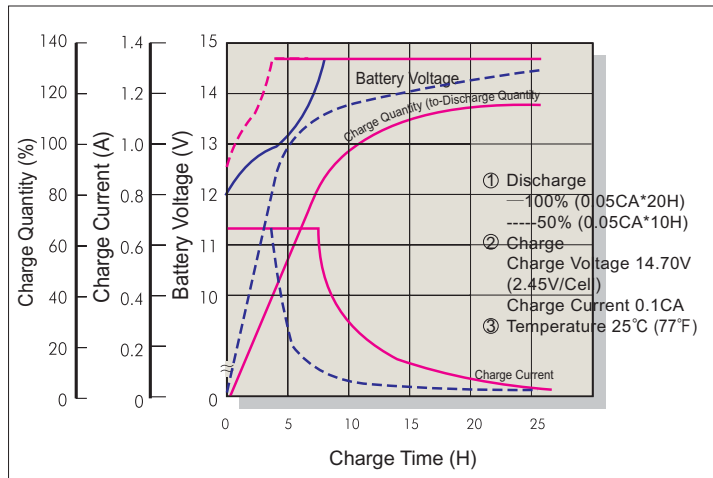

Terminal Voltage (V) and Discharge Time (25°C 77°F)

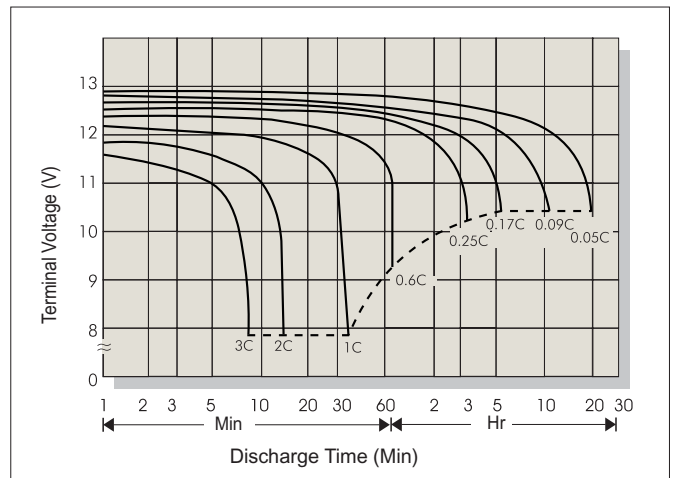

Charging Procedures

Application	Charge Voltage (V/Cell)			Max. Charge Current
	Temperature	Set Point	Allowable Range	
Cycle Use	25°C (77°F)	2.45	2.40-2.50	0.3C
Standby	25°C (77°F)	2.275	2.25-2.30	

Discharge Current VS. Discharge Voltage

Final Discharge Voltage V/Cell	1.75	1.70	1.55	1.30
Discharge Current (A)	0.2C>(A)	0.2C<(A)<0.5C	0.5C<(A)<1.0C	(A)>1.0C